

FUMEX®

OF

Oil mist filter

FUMEX OF is an oil mist filter for airflows ranging from 400m³/h to 8,000m³/h, with 2- and 3- stage filtration.

FUMEX OF is used for the filtration of oil and emulsion mist created through, for example, cutting processes such as lathe turning, milling, drilling, wet grinding and spark suppression (not oil smoke).

The OF Filter is built in accordance with the modular principle. The system can therefore easily be expanded with additional modules as needs change.

The filter is available with- or without a fan.

The filter is very user-friendly and requires little maintenance. All filters feature easy-to-read pressure drop meters as standard for every filter unit, these will show when it is time to change the filter.

All filters are equipped with an outlet for drainage. The oil can be fed back to the machine or collected in a container.

The units can be used together with Fumex control equipment with motorised dampers and automatic controls, which serve to optimise filtration.

Air and heat can be fed back to the facility, which allows for reusable energy.



The Fumex product line also includes fans, accessories, automatic controls, and filters

FILTER
Clear advantages

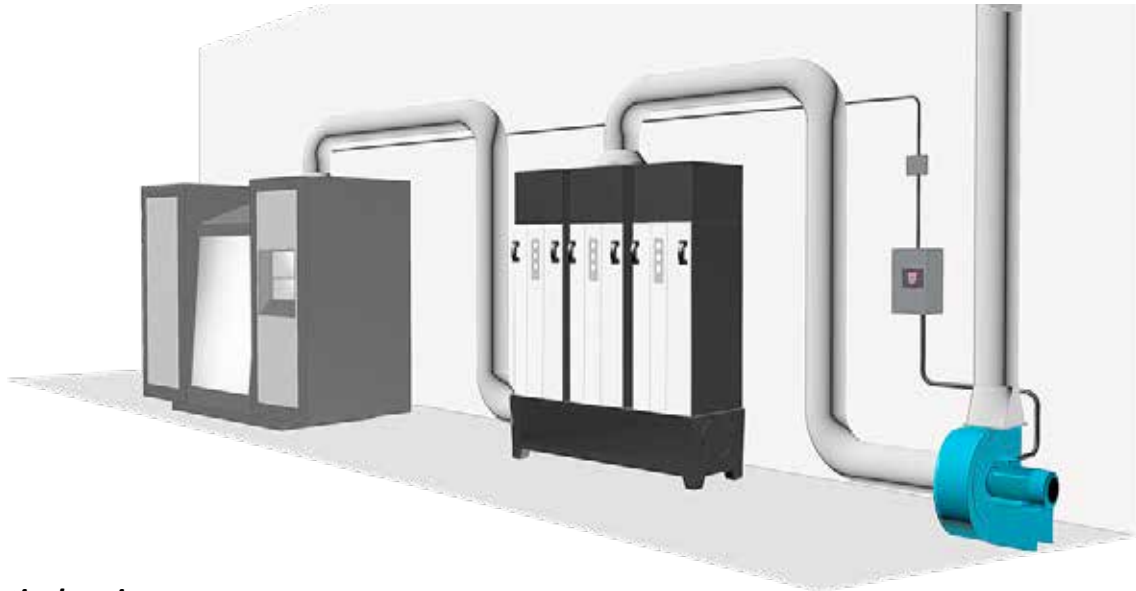

Schematic drawing

Oil mist filter OF connected to a lathe equipped with an automatic damper. The fan’s rotational speed is adjusted by a pressure sensor and a frequency converter. This type of control makes it possible to maintain a needs-adjusted airflow from the lathe with 0.1m/s in the slot opening with the door closed and approx. 0.5m/s in the opening with the door open. A switch in the lathe door sends a signal to the control unit (S 400) to open or close the motorised damper (SAS-160) and to send a signal to the frequency converter, which by means of a pressure sensor (ST 300) detects the pressure change in the duct and raises or lowers the rotational speed of the fan.

This design solution helps increase the service life of the filter and also saves energy, because the fan's rotational speed is adapted to how long the door is left open.

When the filter is equipped with a HEPA filter, the air can recirculate into the facility, resulting in additional energy savings.

All models (with the exception of OMF) are available with- or without an integrated fan.

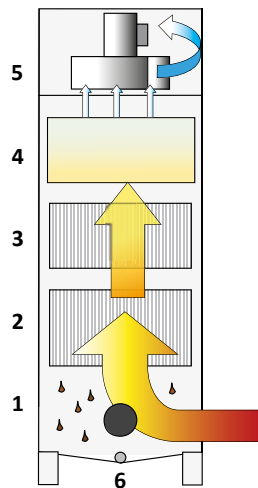

How the oil mist filter works

1. **Inlet.** Optionally left or right
2. **Base filter.** Fibreglass filter with aluminium separators EU5. Should be replaced at a pressure of 500 Pa
3. **Fine filter** Fibreglass filter with aluminium separators EU9. Should be replaced at a pressure of 500 Pa
4. **HEPA filter** H13. Filtration level greater than 99%, not washable but easily replaceable. Should be replaced at a pressure of 800 Pa
5. **Fan**
6. **Drainage** left or right

Filter types

	Combination cartridge OEU5/9-6	HEPA filter OH13
Mobi-oil	4.5m ² + 4.5m ²	9m ²
OF 400	3m ² + 3m ²	6m ²
OF 600	4.5m ² + 4.5m ²	9m ²
OF 1000	8m ²	22m ²

	Base filter OEU5	Fine filter OEU5/9-6	HEPA filter OH13
OF 2000	10m ²	8m ²	22m ²
OF 4000	21m ²	15m ²	44m ²
OF 6000	30m ²	24m ²	66m ²
OF 8000	42m ²	30m ²	88m ²

Fumex OF-filter intended for oil mist

Oil mist is usually comprised of large particles consisting of drops of oil or water emulsion. Oil mist is generated when coolant is sprayed on rotating parts during lathing, milling and drilling in metal.

Filter efficiency

The oil mist filter delivers a very high rate of filtration due to the combination of effective prefilter and a HEPA filter as an end filter.

The first filter separates large particles and droplets.

The next filter separates out the majority of the oil mist.

The end filter, which is a so-called HEPA filter, separates out the finest particles.

The air can then usually be recirculated into the workshop facilities.

The total level of separation for the OF filter is greater than 99%.

A HEPA filter cartridge is included as part of the standard delivery.

Operations and Maintenance

Minimal maintenance is required thanks to the unit's design with self-draining filter cartridges.

The filter is equipped with a pressure meter that indicates the status of every filter cartridge.

The filter is usually changed after 1-2 years of operation.

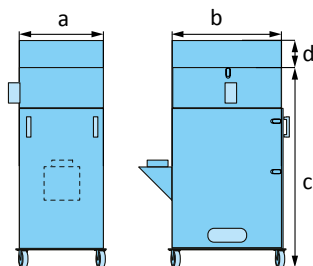

OMF

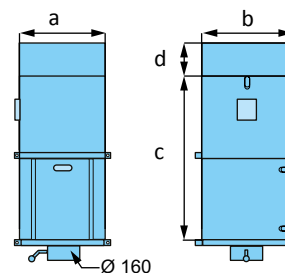

OF 400/OF 600

Item	a (mm)	b (mm)	c (mm)	d (mm)	Motor output (kW)		Weight (kg)
OMF	500	650	1235		0,75	-1 -3 fas	80
OMF H	500	650	1435	200		-1 -3 fas	
OF 400	420	440	800				30
OF 600	500	535	770				39
OF 400 F	420	440	800		0,37 / 0,75	-1 -3 fas	48
OF 600 F	500	535	770		0,37 / 0,75	-1 -3 fas	64
OF 400 H	420	440	1000				34
OF 600 H	500	535	970				45
OF 400 FH	420	440	800	200	0,37 / 0,75	-1 -3 fas	52
OF 600 FH	500	440	970	200	0,37 / 0,75	-1 -3 fas	70

F = Fan

H = HEPA-filter

FUMEX® OF

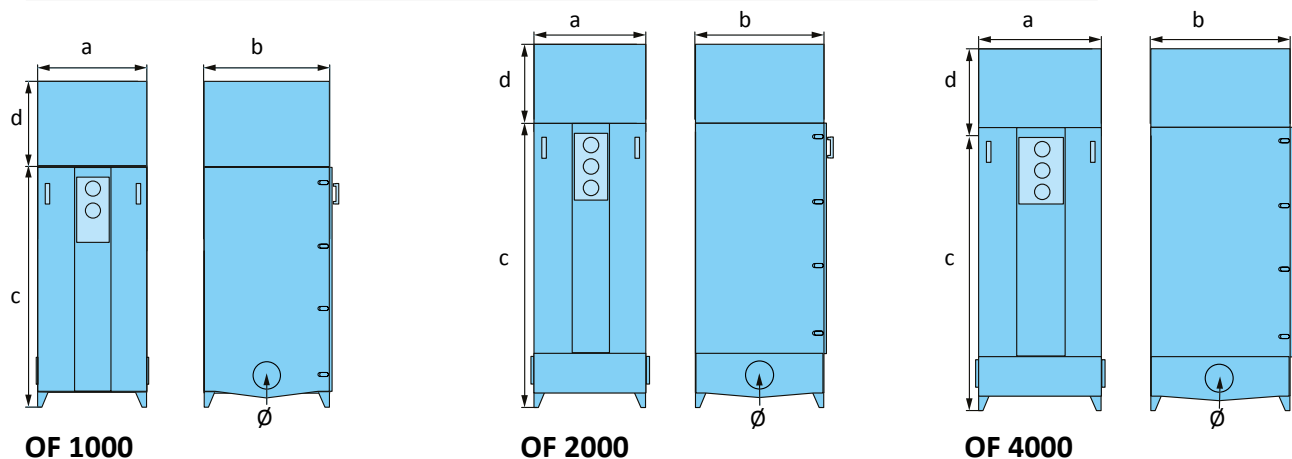

OF 1000

OF 2000

OF 4000

Artikel	a (mm)	b (mm)	c (mm)	d (mm)	Ø (mm)	Motor output (kW)	Max airflow (m³/h)	Weight (kg)
OF 1000	640	735	1270	-	160	-	1000	134
OF 2000	640	735	1610	-	200	-	2000	176
OF 4000	800	900	1585	-	315	-	4000	248
OF 1000 F	640	735	1270	500	160	1,1	1000	134
OF 2000 F	640	735	1610	500	200	2,2	2000	176
OF 4000 F	800	900	1585	540	315	4,0	4000	248

F = Fan

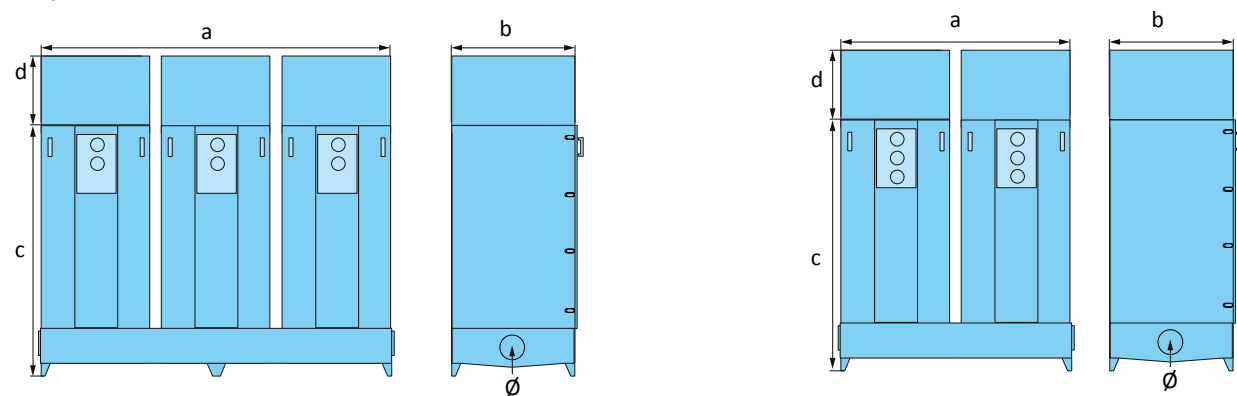

OF 6000

OF 8000

Artikel	a (mm)	b (mm)	c (mm)	d (mm)	Ø (mm)	Motor output (kW)	Max airflow (m³/h)	Weight (kg)
OF 6000	2120	735	1635	-	400	-	6000	447
OF 8000	1700	900	1635	-	400	-	8000	426
OF 6000 F	2120	735	1635	500	400	3 X 2,2	6000	522
OF 8000 F	1700	900	1635	540	400	2 X 4,0	8000	496

F = Fan

Filter housing

Filter housing in powder-coated sheet metal

Filter

Cartridge filter, fibreglass material

Accessories

Extension leg 0.2m for OF 400-600

Extension leg 0.4m for OF 400-600

Extension leg 0.5m for OF 1000-8000

As delivered

The filter is delivered assembled.

Other

Surface treatment
of sheet metal pieces

Powder coating

FUMEX®

Verkstadsvagen 2, 931 61 SKELLEFTEÅ, Sweden
Skelleftea: Tel. 0910-361 80, Fax 0910-13022
www.fumex.com info@fumex.se